

## SPECIFICATIONS THC5000

### Three ranges

0 -1 ppm	Display resolution 0.01 ppm
0 -10 ppm	Display resolution 0.1 ppm
0 -100 ppm	Display resolution 0.1 ppm
Accuracy	0.5 % at full scale
Detection limit	< 0.05 ppm for the range 0-1 ppm

Drift 1% over 24 hours

Sample flow +/- 3 l/h

Max. input pressure Working pressure from 0.3 to 15 Bar

### Sampling gas **N<sub>2</sub>, Ar, He, Air, H<sub>2</sub> or CO<sub>2</sub>**

Sample gas connection 1/8" Swagelok SS

Sample flow rate Approximately 3 l/h

Sample pressure from 0.3 to 15 Bar

### Combustive gas **Synthetic air**

Combustive gas connection 1/8" Swagelok SS

Combustive gas pressure 2 Bar

Combustive gas flow rate 20 l/h

Recommended quality 5.0

### Fuel gas **Hydrogen or 40% Hydrogen and 60% Nitrogen mixture**

Fuel gas connection 1/8" Swagelok SS

Fuel gas pressure 1 Bar

Fuel gas flow rate 2 l/h

Recommended quality 6.0

Operating temperature ± 20°C without wide temperature variations

Power supply 220 Vac, 50-60 Hz

Power consumption 500 VA

4-20 mA output 1 output for THC

RJ-45 connection Computerised system maintenance

Output relays (dry contacts, SPST 2A / 250 VAC)  
 1 STATUS contact relay (security alarm)  
 3 RANGE contact relays (active range)  
 1 process alarm contact relay (level 1)  
 1 process alarm contact relay (level 2)  
 2 contacts for automatic calibration

## Dimensions

Standard rack mount 4U  
 Height > 178 mm | Depth > 450 mm | Width > 483 mm

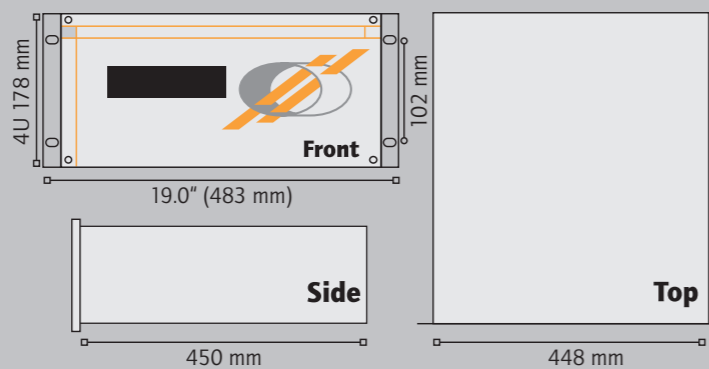

sales@  
www.orthodyne.be

# Line 5000



# THC5000

Continuous THC analyser

Analysis of **THC** in **PPM** level



Avenue de l'Union 25A - B-4430 ANS - BELGIUM  
 Phone : +32-4-263 90 90 - Fax : +32-4-263 09 79  
 E-Mail : sales@orthodyne.be

# THC5000

## Continuous THC analyser

The THC5000 is a continuous analytical system that measures the total hydrocarbon (THC) in ppm level in various gases, such as Oxygen, Air, Carbon Dioxide, Nitrogen, Argon, Helium and Hydrogen.

### PRINCIPLE

The THC 5000 module is composed of a flame ionization detector placed in a temperature regulated chamber and coupled with a continuous analysing technology.

Burning of the components containing hydrocarbons by the hydrogen flame generates an ion current proportional to the impurities introduced into the gas to be analysed.

This analyser is a standard 19 inch rack module, 4U in height and 450 mm in depth.

One analog 4-20 mA output provides the total concentration of hydrocarbons impurities.

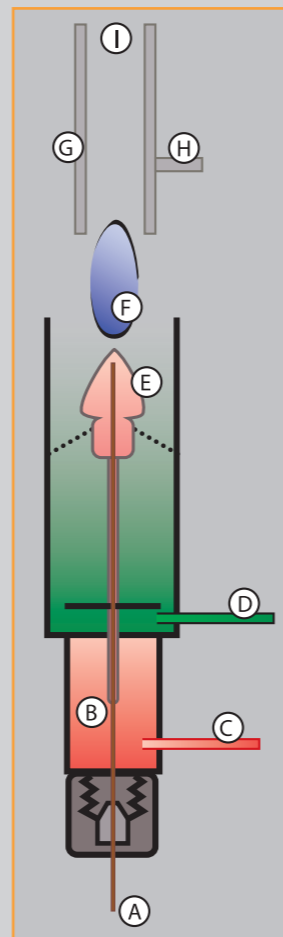

### FID DETECTOR EXPLANATION

The above diagram shows the general construction of a FID.

Organic compounds from the separation column are injected into the detector housing where they are mixed with Hydrogen and Synthetic Air before entering the detector nozzle where the mixture is burned.

During this process, organic compounds are broken down into carbon fragments and acquire a positive charge (i.e., become ionized) at the surface of the anode.

Carbon fragments are detected by the collector.

The signal is then amplified and sent to the data processing system.

- A > Sample inlet
- B > Mixture between the sample and the Hydrogen
- C > Hydrogen inlet
- D > Synthetic Air inlet
- E > Nozzle
- F > Flame tip
- G > Collector
- H > Anode & Ignitor
- I > Flame guard

### FEATURES

- < 50 ppb resolution guaranteed on the 0-1 ppm. (quantification level limit)
- Total Hydrocarbons from C1 to C5.
- Electronic flame-out guard circuit.
- Automatic fuel shut off system.
- Easy to use.
- Low sample flow.
- Lower power consumption.
- Alphanumeric screen 8 x 40 characters, 64 x 240 pixels.
- Adjustable alarm and oven settings.
- Fast response.
- Multifunctional and real-time software.
- CE marked.



### Type of configuration

- **THC 5000** : Continuous analyser of THC in Air, Carbon Dioxide, Nitrogen, Argon, Helium and Hydrogen.
- **THC 5005** : Continuous analyser of THC in Oxygen.\*
- **THC 5010** : Continuous analyser of THC in Oxygen or in other gases (Air, Carbon Dioxide, Nitrogen, Argon, Helium, Hydrogen).\*

\* Require a special feeding gas mixture (40 % Hydrogen and 60 % Nitrogen)

### Applications

- Air separation plants
- Gas purity certification
- Specialty gas laboratories
- Process control
- Steel industry

### System overview

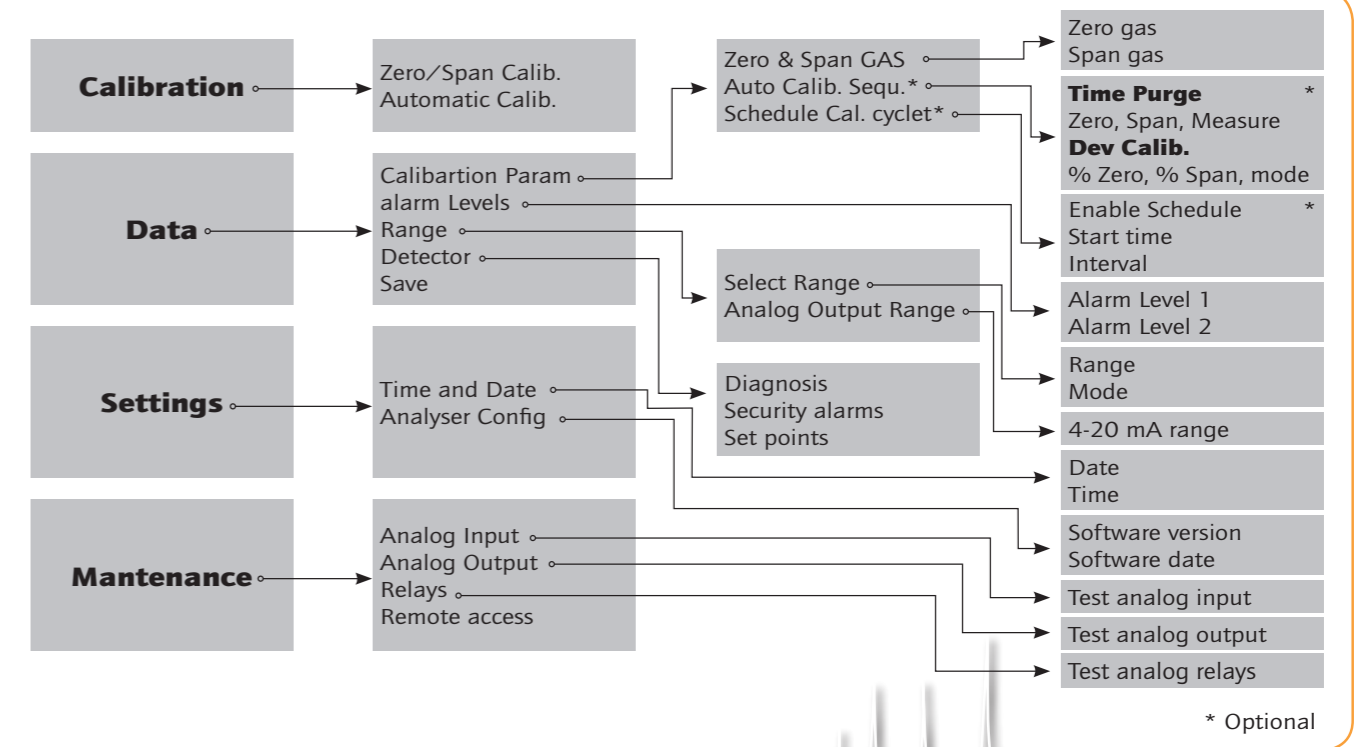

Line 5000 - THC 5000 - Continuous THC analyser